

Архангельск (8182)63-90-72  
 Астана (7172)727-132  
 Астрахань (8512)99-46-04  
 Барнаул (3852)73-04-60  
 Белгород (4722)40-23-64  
 Брянск (4832)59-03-52  
 Владивосток (423)249-28-31  
 Волгоград (844)278-03-48  
 Вологда (8172)26-41-59  
 Воронеж (473)204-51-73  
 Екатеринбург (343)384-55-89  
 Иваново (4932)77-34-06

Ижевск (3412)26-03-58  
 Иркутск (395)279-98-46  
 Казань (843)206-01-48  
 Калининград (4012)72-03-81  
 Калуга (4842)92-23-67  
 Кемерово (3842)65-04-62  
 Киров (8332)68-02-04  
 Краснодар (861)203-40-90  
 Красноярск (391)204-63-61  
 Курск (4712)77-13-04  
 Липецк (4742)52-20-81

Магнитогорск (3519)55-03-13  
 Москва (495)268-04-70  
 Мурманск (8152)59-64-93  
 Набережные Челны (8552)20-53-41  
 Нижний Новгород (831)429-08-12  
 Новокузнецк (3843)20-46-81  
 Новосибирск (383)227-86-73  
 Омск (3812)21-46-40  
 Орел (4862)44-53-42  
 Оренбург (3532)37-68-04  
 Пенза (8412)22-31-16

Пермь (342)205-81-47  
 Ростов-на-Дону (863)308-18-15  
 Рязань (4912)46-61-64  
 Самара (846)206-03-16  
 Санкт-Петербург (812)309-46-40  
 Саратов (845)249-38-78  
 Севастополь (8692)22-31-93  
 Симферополь (3652)67-13-56  
 Смоленск (4812)29-41-54  
 Сочи (862)225-72-31  
 Ставрополь (8652)20-65-13

Сургут (3462)77-98-35  
 Тверь (4822)63-31-35  
 Томск (3822)98-41-53  
 Тула (4872)74-02-29  
 Тюмень (3452)66-21-18  
 Ульяновск (8422)24-23-59  
 Уфа (347)229-48-12  
 Хабаровск (4212)92-98-04  
 Челябинск (351)202-03-61  
 Череповец (8202)49-02-64  
 Ярославль (4852)69-52-93

Киргизия (996)312-96-26-47

Россия (495)268-04-70

Казахстан (772)734-952-31

<https://opacmare.nt-rt.ru/> || [omp@nt-rt.ru](mailto:omp@nt-rt.ru)

## SLIDER LIFT 5410



model	A (mm/ inch)	B (mm/ inch)	C (mm/ inch)	D (mm/ inch)	E (mm/ inch)	S (mm/ inch)	L (mm/ inch)	M (mm/ inch)	dynamic load (kg/ lbs)
5410/96	775 30"1/2	360 37"4/5	1590 62"3/5	2815 110"4/5	3100 122"	250 10"	1505 59"1/4	360 14"1/5	800 1763

**POSSIBLE CUSTOMIZATION OF DIMENSIONS**

The purpose of this system is to haul and shelter a tender or a jet ski up to 2000 kg.

This mechanism makes it possible to obtain a twice as wide surface compared to the original platform area.

The platform rotation moves the platform away from the propellers or from the boat movement systems.

SLIDERLIFT system can be fitted on any type of boat, both as refit and first installation, allowing you to enjoy an increased walkway surface on your boat.

Customisations can be made according to your boat design.

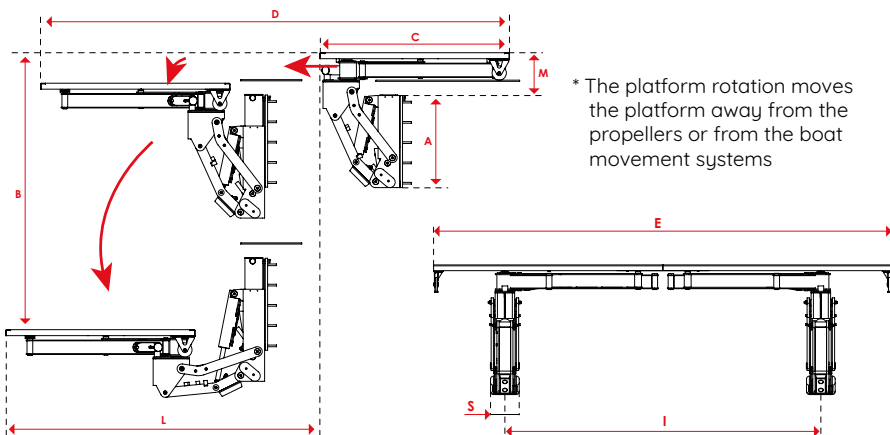

\*Teak not included

Архангельск (8182)63-90-72  
 Астана (7172)727-132  
 Астрахань (8512)99-46-04  
 Барнаул (3852)73-04-60  
 Белгород (4722)40-23-64  
 Брянск (4832)59-03-52  
 Владивосток (423)249-28-31  
 Волгоград (844)278-03-48  
 Вологда (8172)26-41-59  
 Воронеж (473)204-51-73  
 Екатеринбург (343)384-55-89  
 Иваново (4932)77-34-06

Ижевск (3412)26-03-58  
 Иркутск (395)279-98-46  
 Казань (843)206-01-48  
 Калининград (4012)72-03-81  
 Калуга (4842)92-23-67  
 Кемерово (3842)65-04-62  
 Киров (8332)68-02-04  
 Краснодар (861)203-40-90  
 Красноярск (391)204-63-61  
 Курск (4712)77-13-04  
 Липецк (4742)52-20-81

Киргизия (996)312-96-26-47

Магнитогорск (3519)55-03-13  
 Москва (495)268-04-70  
 Мурманск (8152)59-64-93  
 Набережные Челны (8552)20-53-41  
 Нижний Новгород (831)429-08-12  
 Новокузнецк (3843)20-46-81  
 Новосибирск (383)227-86-73  
 Омск (3812)21-46-40  
 Орел (4862)44-53-42  
 Оренбург (3532)37-68-04  
 Пенза (8412)22-31-16

Россия (495)268-04-70

Пермь (342)205-81-47  
 Ростов-на-Дону (863)308-18-15  
 Рязань (4912)46-61-64  
 Самара (846)206-03-16  
 Санкт-Петербург (812)309-46-40  
 Саратов (845)249-38-78  
 Севастополь (8692)22-31-93  
 Симферополь (3652)67-13-56  
 Смоленск (4812)29-41-54  
 Сочи (862)225-72-31  
 Ставрополь (8652)20-65-13

Казахстан (772)734-952-31

Сургут (3462)77-98-35  
 Тверь (4822)63-31-35  
 Томск (3822)98-41-53  
 Тула (4872)74-02-29  
 Тюмень (3452)66-21-18  
 Ульяновск (8422)24-23-59  
 Уфа (347)229-48-12  
 Хабаровск (4212)92-98-04  
 Челябинск (351)202-03-61  
 Череповец (8202)49-02-64  
 Ярославль (4852)69-52-93

<https://opacmare.nt-rt.ru/> || [omp@nt-rt.ru](mailto:omp@nt-rt.ru)

## SLIDER LIFT 5420

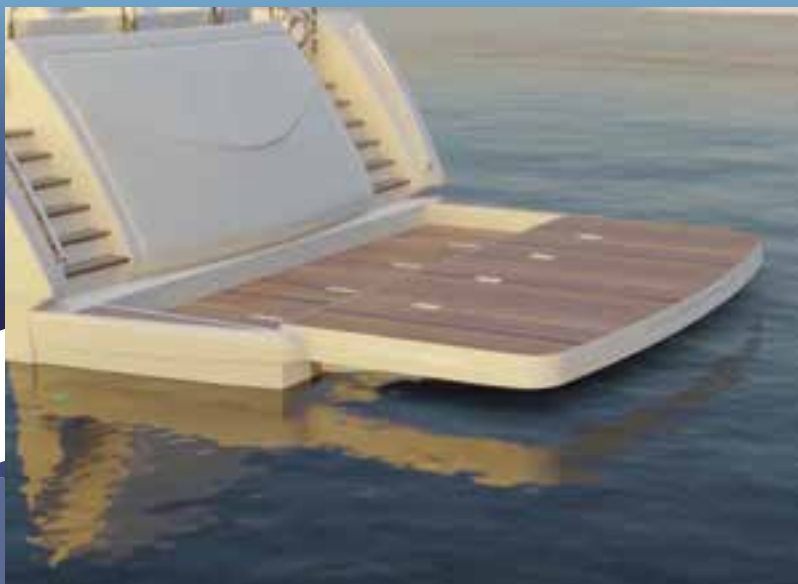

model	A (mm/ inch)	B (mm/ inch)	C (mm/ inch)	D (mm/ inch)	E (mm/ inch)	S (mm/ inch)	L (mm/ inch)	M (mm/ inch)	dynamic load (kg/ lbs)
5420/90	790 31"	900 35"2/5	1590 62"3/5	2815 110"4/5	3100 122"	190 7"1/2	1210 47"3/5	345 13"1/2	800 1763

**POSSIBLE CUSTOMIZATION OF DIMENSIONS**

The purpose of this system is to haul and shelter a tender or a jet ski up to 2000 kg.

This mechanism makes it possible to obtain a twice as wide surface compared to the original platform area.

The platform rotation moves the platform away from the propellers or from the boat movement systems.

SLIDERLIFT system can be fitted on any type of boat, both as refit and first installation, allowing you to enjoy an increased walkway surface on your boat.

Customisations can be made according to your boat design.

